

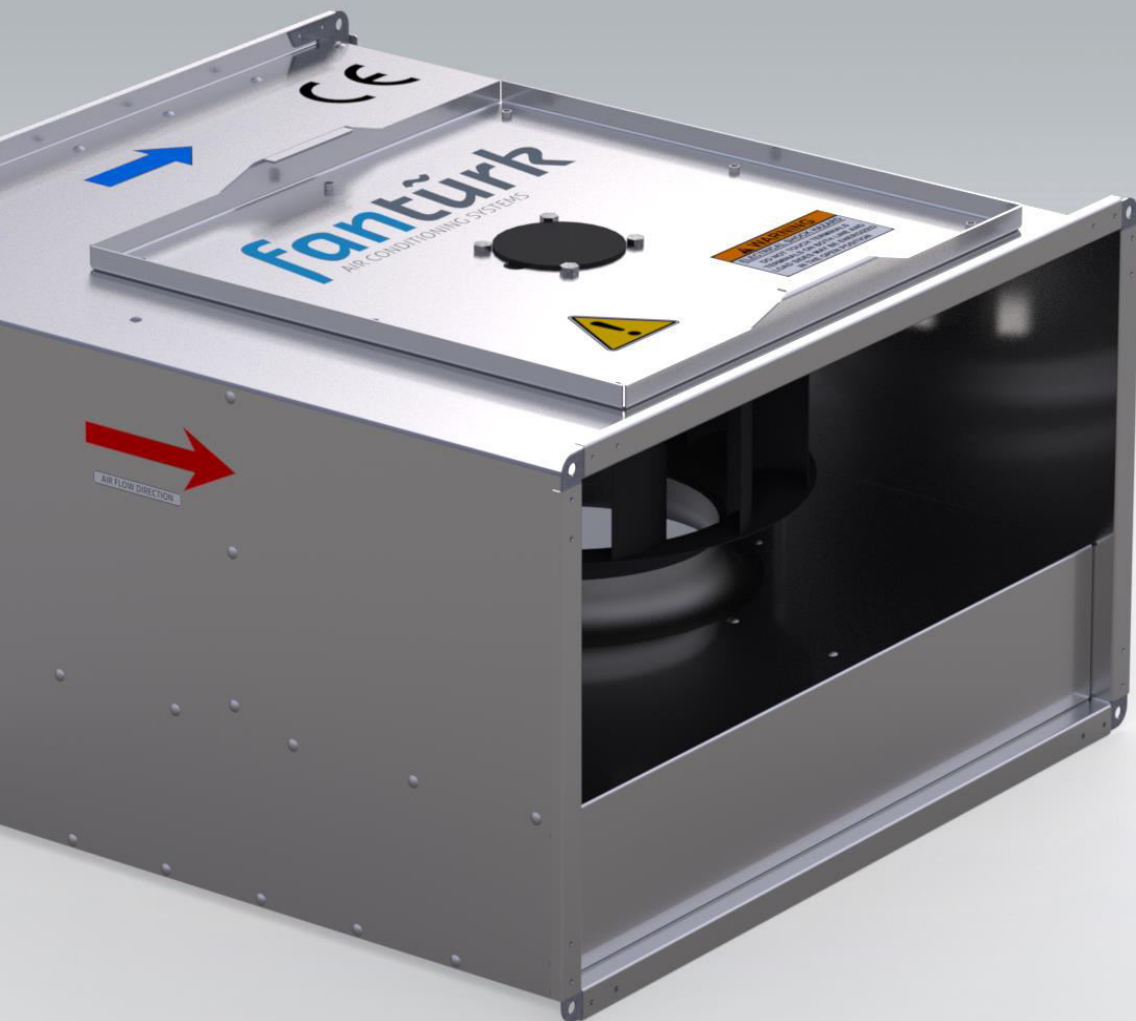

# ***Product Catalogue***



***D-KTF***  
***Rectangular Duct***  
***Type In-Line Fan***



## Technical Specifications

# RECTANGULAR DUCT TYPE IN-LINE FAN

D-KTF series rectangular duct type radial fans; They are the ideal fans for ducted ventilation systems where high air flow and high pressure are required. Thanks to their compact construction, they can be installed directly in the air ducts without the need for large bends and transducers in any position required. D-KTF series in-line fans are the ideal choice for high performance and trouble-free operation.

Made of high quality corrosion resistant galvanized steel. Fans are radial fans with backward curved blades. Thanks to the service cover, the fan can carry out maintenance without removing the duct connection. Motors are single phase and has IP55 and Class F insulation. Speed controller is optional for all models.

### Usage Areas

Can be used for ventilation systems in industrial buildings, kitchens, toilets, swimming pools, gyms, warehouses, hospitals, offices, laboratories, shopping malls, restaurants, theaters, residential buildings.

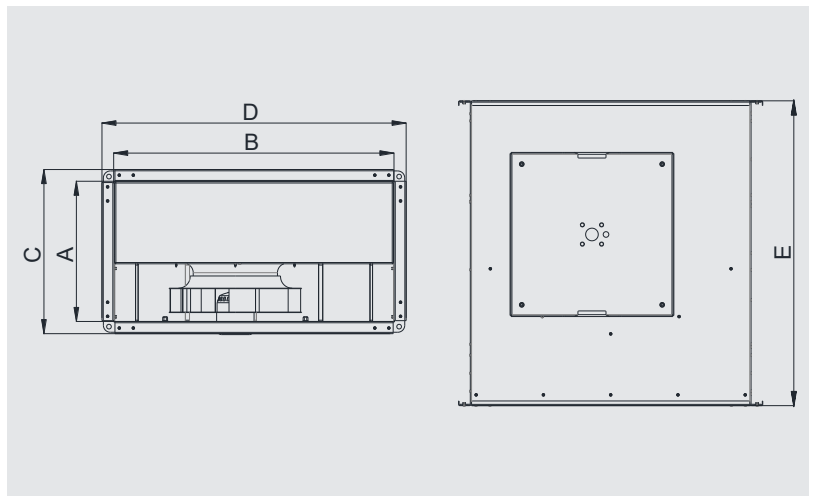

MODEL	A	B	C	D	E	VOLTAGE	FREQUENCY	POWER	CURRENT	CAPACITOR	MOTOR SPEED	AIR FLOW RATE	SOUND LEVEL	WEIGHT
	mm	mm	mm	mm	mm	V	Hz	W	A	µf	rp m	m <sup>3</sup> /h	dBA	kg
D-KTF 30 - 15	150	300	200	350	400	230	50	66	0,3	3	2300	540	48	7
D-KTF 40 - 20A	200	400	250	450	500	230	50	100	0,47	3	2580	800	53	11
D-KTF 40 - 20B	200	400	250	450	500	230	50	150	0,65	4	2680	1020	55	12
D-KTF 50 - 25	250	500	300	550	550	230	50	200	0,9	6	2650	1520	56	16
D-KTF 60 - 30	300	600	350	650	650	230	50	250	1,1	8	2500	1840	50	20
D-KTF 60 - 35	350	600	400	650	750	230	50	210	1	8	1400	2520	53	27
D-KTF 70 - 40	400	700	450	750	800	230	50	500	1,8	12	1380	4100	60	38
D-KTF 80 - 50	500	800	550	850	900	230	50	800	3,7	16	1350	5600	64	61
D-KTF 100 - 50	500	1000	550	1050	1050	230	50	1550	6,8	31	1380	7600	66	86

## Performance Curves

### D-KTF 30 - 15

Voltage 230 V  
Frequency 50 Hz  
Motor Power 66 W  
Current 0,3 A  
Capacitor 3  $\mu$ f  
Motor Speed 2300 rpm  
Flow Rate 540 m<sup>3</sup>/h  
Sound Pressure Level 48 dBA  
Weight 7 kg

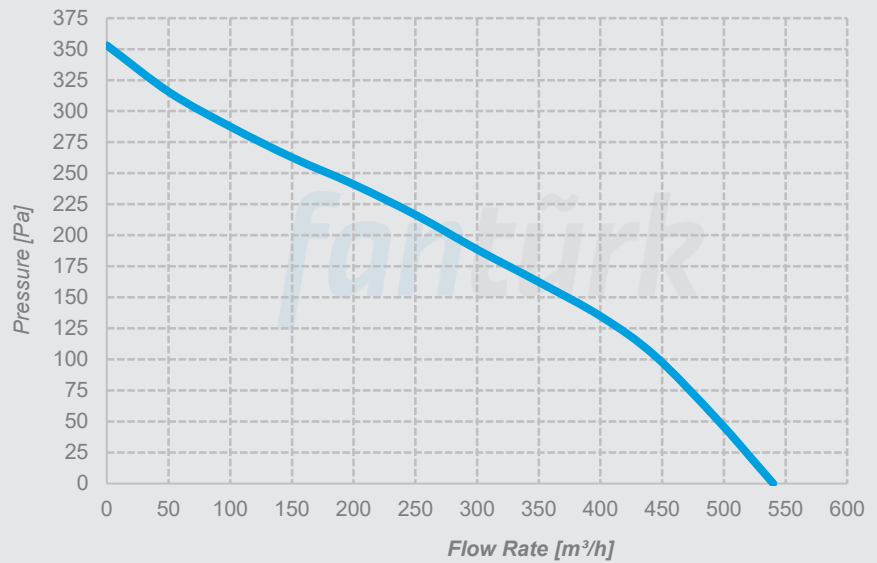

### D-KTF 40 - 20A

Voltage 230 V  
Frequency 50 Hz  
Motor Power 100 W  
Current 0,47 A  
Capacitor 3  $\mu$ f  
Motor Speed 2580 rpm  
Flow Rate 800 m<sup>3</sup>/h  
Sound Pressure Level 53 dBA  
Weight 11 kg

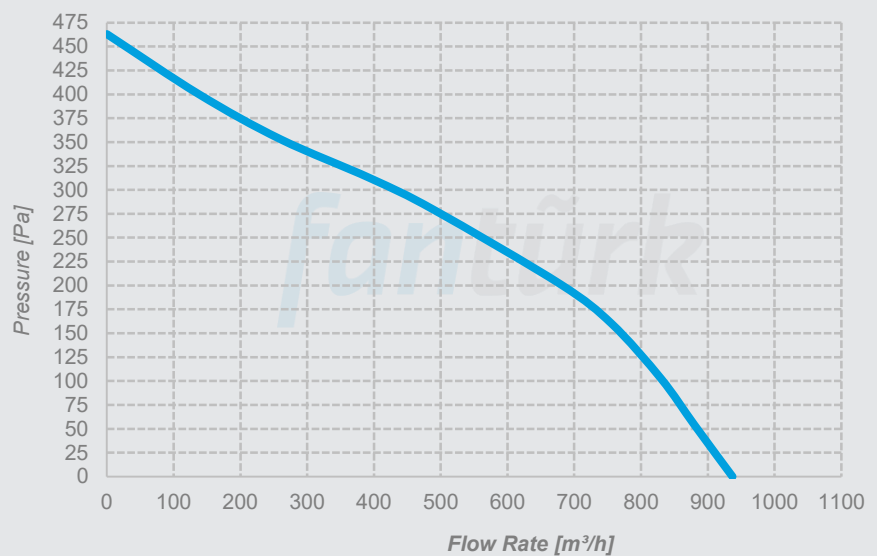

### D-KTF 40 - 20B

Voltage 230 V  
Frequency 50 Hz  
Motor Power 150 W  
Current 0,65 A  
Capacitor 4  $\mu$ f  
Motor Speed 2680 rpm  
Flow Rate 1020 m<sup>3</sup>/h  
Sound Pressure Level 55 dBA  
Weight 12 kg

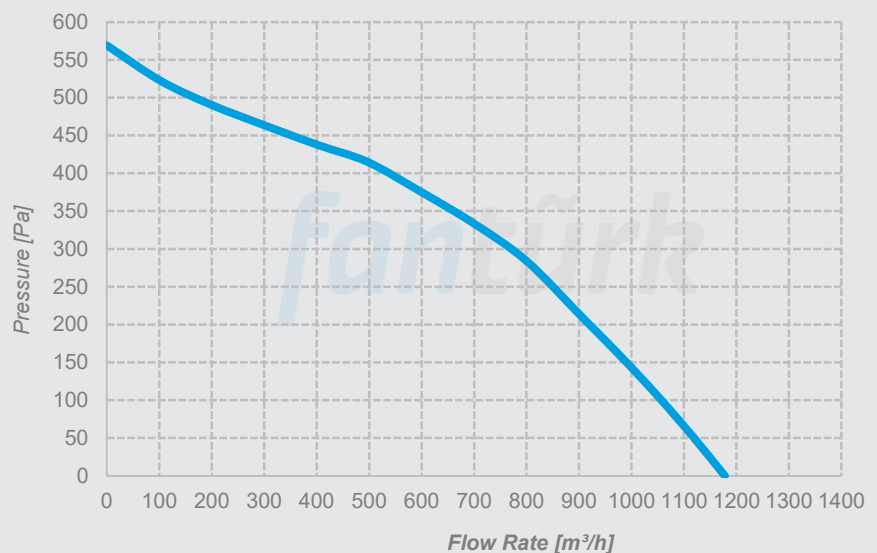

## Performance Curves

### D-KTF 50 - 25

Voltage 230 V  
Frequency 50 Hz  
Motor Power 200 W  
Current 0,9 A  
Capacitor 6  $\mu$ f  
Motor Speed 2650 rpm  
Flow Rate 1520 m<sup>3</sup>/h  
Sound Pressure Level 56 dBA  
Weight 16 kg

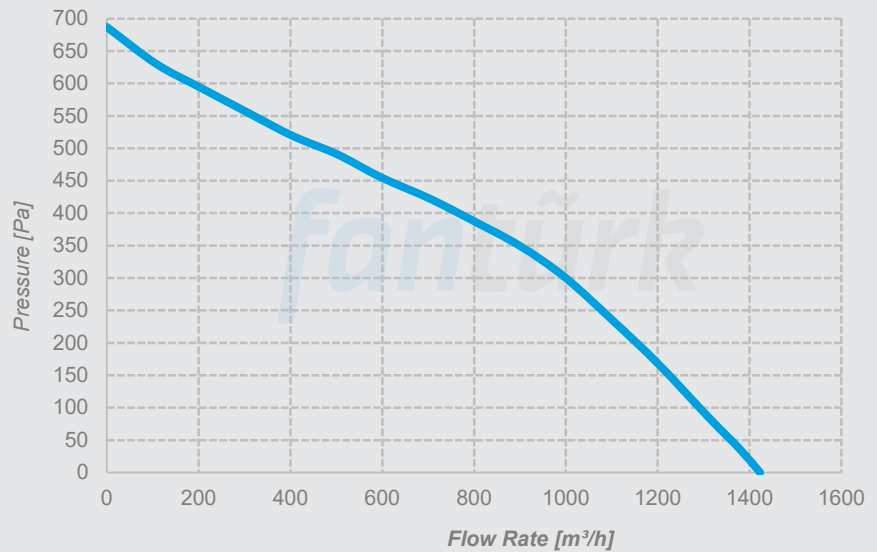

### D-KTF 60 - 30

Voltage 230 V  
Frequency 50 Hz  
Motor Power 250 W  
Current 1,1 A  
Capacitor 8  $\mu$ f  
Motor Speed 2500 rpm  
Flow Rate 1840 m<sup>3</sup>/h  
Sound Pressure Level 50 dBA  
Weight 20 kg

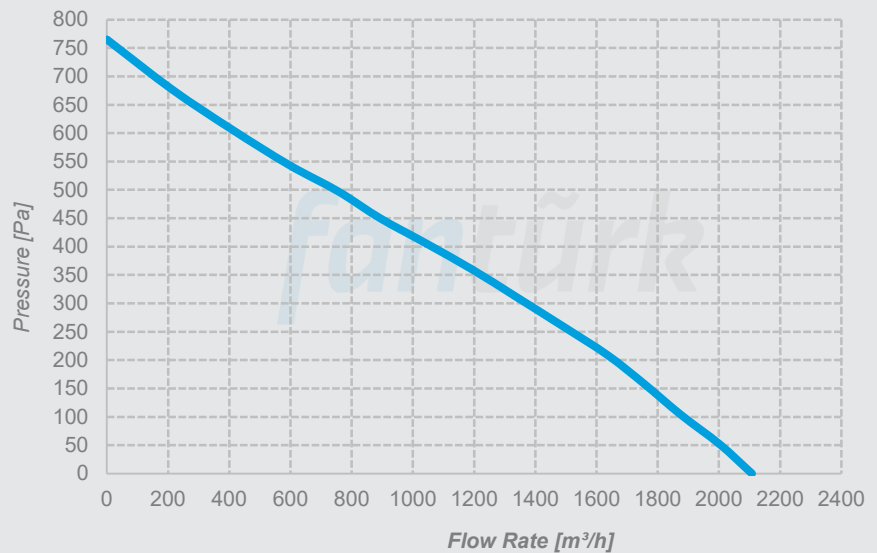

### D-KTF 60 - 35

Voltage 230 V  
Frequency 50 Hz  
Motor Power 210 W  
Current 1 A  
Capacitor 8  $\mu$ f  
Motor Speed 1400 rpm  
Flow Rate 2520 m<sup>3</sup>/h  
Sound Pressure Level 53 dBA  
Weight 27 kg

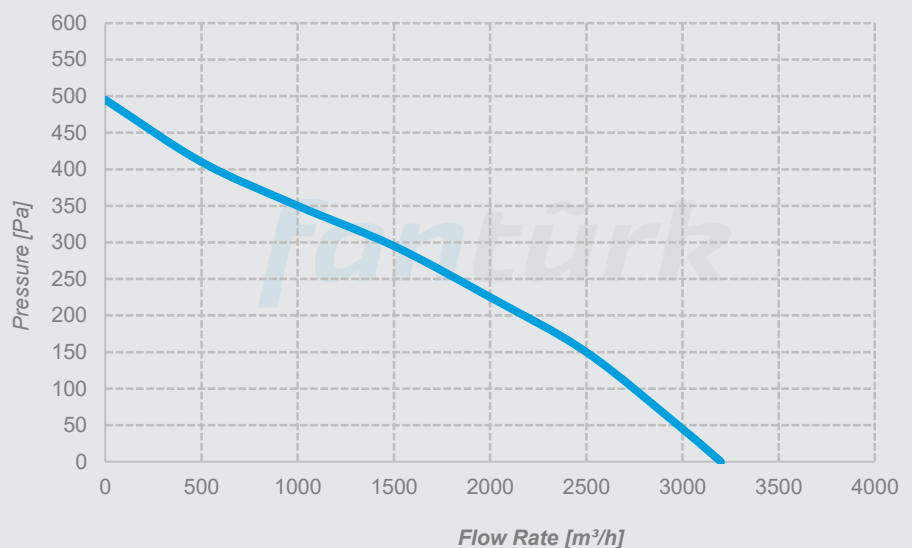

# Performance Curves

## D-KTF 70 - 40

**Voltage** 230 V  
**Frequency** 50 Hz  
**Motor Power** 500 W  
**Current** 1,8 A  
**Capacitor** 12  $\mu$ f  
**Motor Speed** 1380 rpm  
**Flow Rate** 4100 m<sup>3</sup>/h  
**Sound Pressure Level** 60 dBA  
**Weight** 38 kg

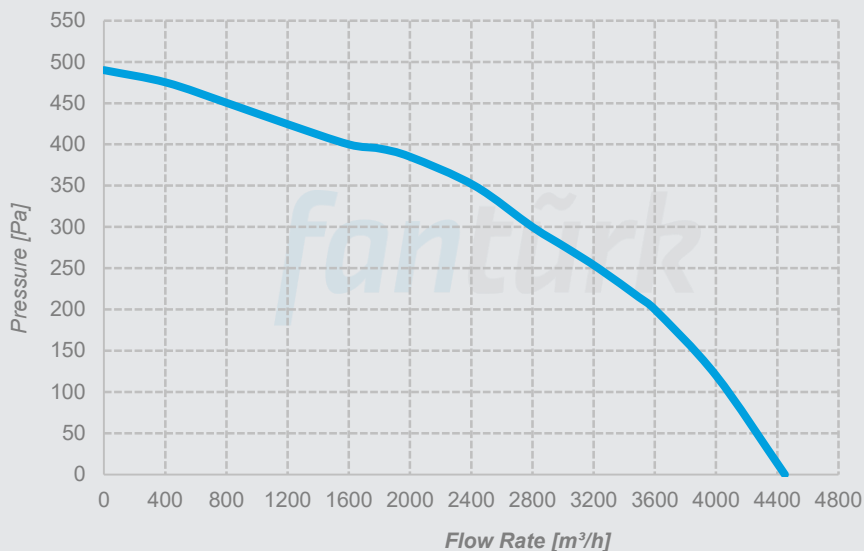

## D-KTF 80 - 50

**Voltage** 230 V  
**Frequency** 50 Hz  
**Motor Power** 800 W  
**Current** 3,7 A  
**Capacitor** 16  $\mu$ f  
**Motor Speed** 1350 rpm  
**Flow Rate** 5600 m<sup>3</sup>/h  
**Sound Pressure Level** 64 dBA  
**Weight** 61 kg

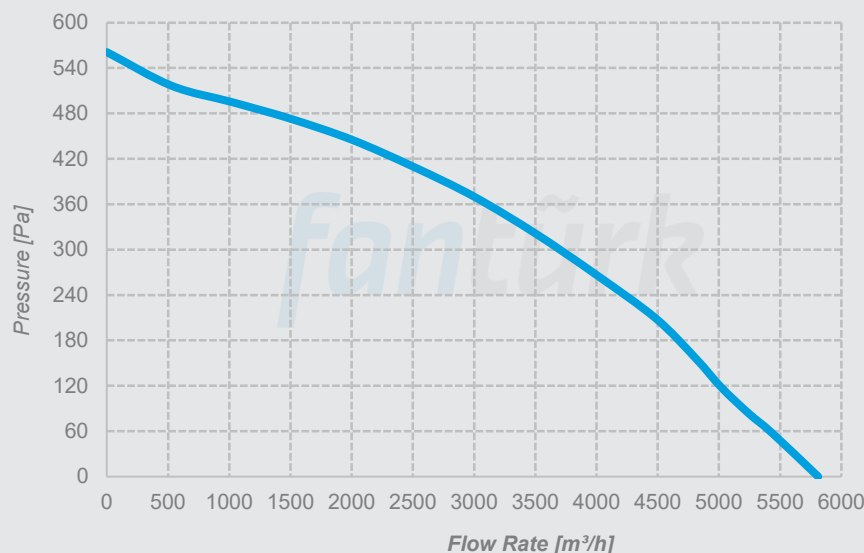

## D-KTF 100 - 50

**Voltage** 230/380 V  
**Frequency** 50 Hz  
**Motor Power** 1550W  
**Current** 6,8 A  
**Capacitor** 31  $\mu$ f  
**Motor Speed** 1380rpm  
**Flow Rate** 7600 m<sup>3</sup>/h  
**Sound Pressure Level** 66 dBA  
**Weight** 86 kg

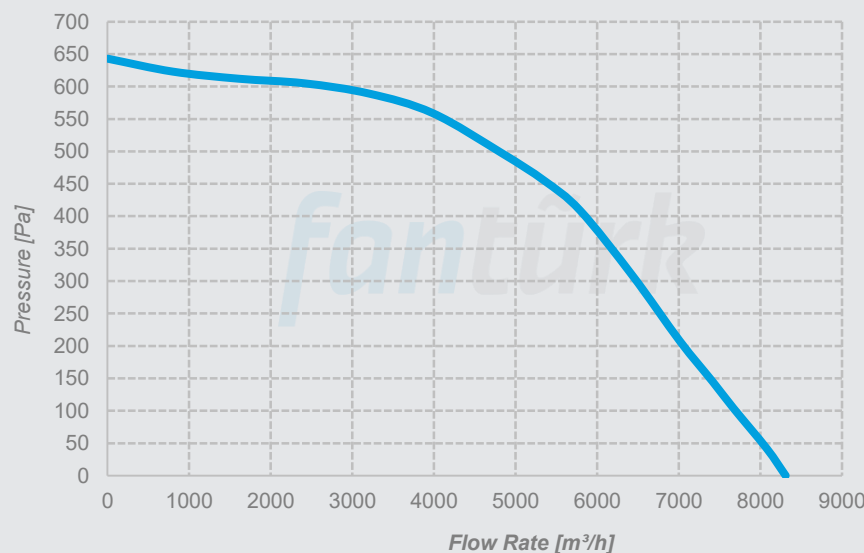

*Minarelicavus OSB District 202. Street No: 19 Nilüfer/Bursa Turkey  
T: 90(224)482 50 95 E: info@fanturk.com.tr*

*fanturk.com.tr*